

## Required material for VENTURA 60 litres

- M10 attachment set, article no. 1143-00
- Drilling machine with drill bit  $\varnothing$  10mm
- Spirit level
- Socket wrench, SW 17

## Required material for VENTURA 110 litres

- M12 attachment set, article no. 1145-00
- Drilling machine with drill bit  $\varnothing$  12mm
- Spirit level
- Socket wrench, SW 19

- 1 Open container, remove securing rod and interior container (Figure 1).
- 2 Place the container at the desired location and mark out the bore pattern. Alternatively, the bore pattern can be marked out as per Figure 2.
- 3 VENTURA 60: Drill  $\varnothing$  10mm holes to a depth of approx. 70mm.  
VENTURA 110: Drill  $\varnothing$  12mm holes to a depth of approx. 90mm.
- 4 Set fixed anchors (see Figure 3). Remove the upper nut along with washer.
- 5 Adjust the lower nut to 25-30mm (the nuts must first be adjusted to the highest point on uneven ground). Then level out the remaining nuts using the spirit level based on the first nut.
- 6 Put the container into position and screw it into place.
- 7 Insert the interior container and fix using the securing rod.

Figure 1: Remove the interior container

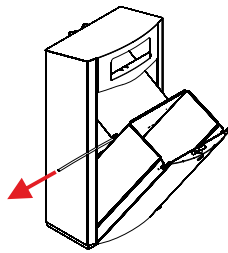
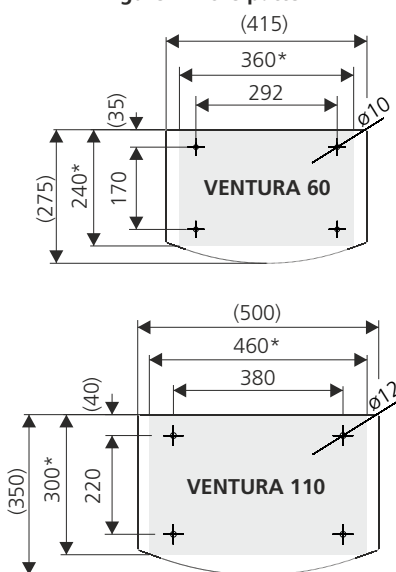
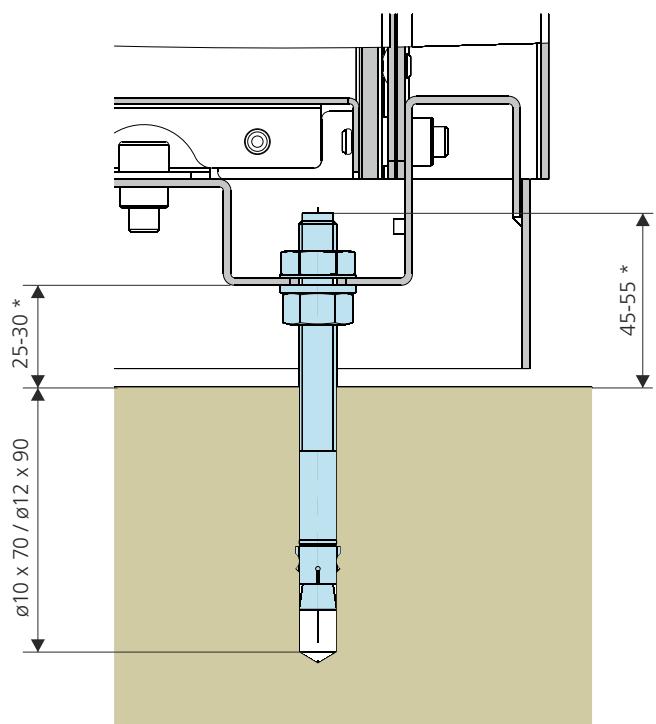

Figure 2: Bore pattern



\* concrete foundation

Figure 3: Cross-section of attachment



\* the stated size is only valid at the highest point on uneven ground

# Post mounting for VENTURA 60 /110 waste bin

15789.2018.01.E.INT

## Required material for VENTURA 60 litres

- Strapping system (e.g. «Bandimex»)
- Allen key 6mm

## Required material for VENTURA 110 litres

- Strapping system (e.g. «Bandimex»)
- Allen key 8mm

- ① Open container, remove securing rod and interior container (Figure 1).
- ② Loosen pipe mounting (Figure 2).
- ③ Set the pipe mounting on the rod or on the candelabra to the desired height (Figure 3).
- ④ Mount the container and screw into place (Figure 4).
- ⑤ Insert the interior container and fix using the securing rod.

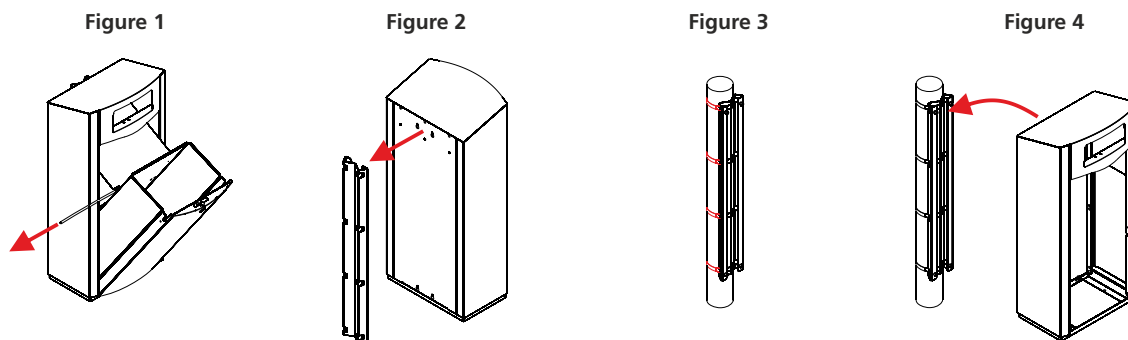

# Wall mounting for VENTURA 60 / 110 waste bin

## Required material for VENTURA 60 litres

- M8 attachment set, article no. 1144-00
- Drilling machine with drill bit  $\varnothing$  8mm
- Spirit level
- Socket wrench, SW 13

## Required material for VENTURA 110 litres

- M10 attachment set, article no. 1143-00
- Drilling machine with drill bit  $\varnothing$  10mm
- Spirit level
- Socket wrench, SW 17

- ① Open container, remove securing rod and interior container.
- ② Mark out the bore pattern in accordance with Figure 1.
- ③ VENTURA 60: Drill  $\varnothing$  8mm holes to a depth of approx. 70mm.  
VENTURA 110: Drill  $\varnothing$  10mm holes to a depth of approx. 90mm.
- ④ Set fixed anchors (see Figure 2)
- ⑤ Put the container into position and screw it into place.
- ⑥ Insert the interior container and fix using the securing rod.

